

UMC Card Access & Electronic Locking Architectural Door Hardware

1. Building survey for Card Access or Electronic Locking:
 - a. What type of door and frame? (Compliant with ADA?)
 - i. Wood, steel or aluminum door
 - ii. Wood, steel (Hollow Metal) or aluminum frame
 - (1) If steel, is the frame grouted full?
 - iii. Single door
 - iv. Pair of doors
 - (1) Is there a center mullion?
 - (a) If so, what are the dimensions?
 - (b) If not, can one be added and still comply with ADA?
 - b. What type of door hardware is existing?
 - i. Rim panic
 - ii. Vertical Rod - concealed or surface?
 - iii. Cylindrical lock set
 - iv. Mortise lock set
 - v. Closer - hold open feature? (Don't use hold open closer if possible)
 - vi. Power operator - low power on demand or full automatic?
 - (1) Controls type and locations.
 - c. What are the surrounding building materials?
 - i. Wall construction - solid or hollow?
 - ii. Ceiling - accessible to above?
 - d. Where are the mechanical spaces?
 - i. How easy will it be to run controls or electrical wiring?

For Card Access, typically, the connections will run to the Anearest@ mechanical space with a Metasys panel. This is usually a mechanical room in the building. (Multiple card access doors may be daisy chained together.)

For Electronic Locking, typically, the connections will run to the Anearest@ mechanical space with available contacts on a control card. This may be a mechanical room or above the ceiling at a VAV box.
 - ii. Contact Energy Management for the preferred location of controls.

UMC Card Access & Electronic Locking Architectural Door Hardware

New components guideline:

The goal in hardware selection is; to have the doors automatically close and lock without human intervention.

2. Card Access Entrance/Electronic Locking

- a. Preferred System with panic exit device. (Any type door and frame.)
 - i. Folger Adam 310-4 x NFS x 24VACSO x PK x LBM x finish electric strike with latch bolt monitor.
 - (1) 110VAC to 24VAC at 40VA transformer.
 - ii. Von Duprin 99NL rim panic with 6" min. straight pull trim.

Or
 - iii. Von Duprin EL99NL electric rim panic on one door and EL99EO on the other door(s), with 6" min. straight pull trim by Von Duprin or by others, >OP=.
 - (1) Von Duprin PS873 power supply. Supplies power for two EL panic devices. For two additional EL panic devices specify PS873-2.
 - (2) Wire transfer (Von Duprin or equal)
 - (a) EPT-2 for new aluminum door systems, butt hinge or offset pivot.
 - (b) DL12 for steel doors and frames or existing aluminum door systems.
 - iv. Magnetic door position switch.
 - (a) Von Duprin MS764 concealed magnetic switch or Folger Adam ASSW05A concealed magnetic switch.
 - v. A 12" x 12" x 6" junction box located above the ceiling, near the door. See detail for conduit and wire sizes.
- b. System with cylinder lock set.
 - i. Von Duprin or Folger Adam electric strike with latch monitor.
 - (1) Steel frame
 - (a) Folger Adam 712-75 x NFS x 24VACSO x LBM x finish or VonDuprin 6211 x FSE x DS x SO24 x finish
 - (b) 110VAC to 24VAC at 40VA transformer.
 - (2) Wood frame (4" to 4 2" mounting depth required)
 - (a) Folger Adam 732-75 x NFS x 24VACSO x LBM x finish or VonDuprin 6211WF x FSE x DS x SO24 x finish
 - (b) 110VAC to 24VAC at 40VA transformer.
 - ii. Best 93K-7-D-14D-N/A-finish
 - iii. A 12" x 12" x 6" junction box located above the ceiling, near the door. See detail for conduit and wire sizes.

UMC Card Access & Electronic Locking Architectural Door Hardware

- c. System with mortise lock set.
 - i. Von Duprin or Folger Adam electric strike with latch monitor.
 - (1) Steel frame
 - (a) Folger Adam 712-75 x NFS x 24VACSO x LBM x finish or VonDuprin 6211 x FSE x DS x SO24 x finish
 - (b) 110VAC to 24VAC at 40VA transformer.
 - (2) Wood frame
 - (a) Folger Adam 732-75 x NFS x 24VACSO x LBM x finish or VonDuprin 6211WF x FSE x DS x SO24 x finish
 - (b) 110VAC to 24VAC at 40VA transformer.
 - ii. Best 35H-7-EW-14-M-finish-door hand
 - iii. A 12" x 12" x 6" junction box located above the ceiling, near the door. See detail for conduit and wire sizes.

- d. System for pair of doors with 2" fixed center mullion.
 - i. Use APreferred System@

- e. System for pair of doors with 2" removable center mullion.
 - i. Use APreferred System@
 - ii. Von Duprin KR9854 x SP28 sprayed aluminum or SP313 sprayed dark duranodic

- f. System for pair of doors with center mullion less than 2" wide, fixed or removable.
 - i. First opening
 - (1) Folger Adam 310-4 x NFS x 24VACSO x PK x LBM x finish electric strike with latch bolt monitor.
 - (2) 110VAC to 24VAC at 40VA transformer.
 - (3) Von Duprin 99NL rim panic with 6" min. straight pull trim.
 - ii. Second opening
 - (1) Von Duprin EL99EO electric rim panic, 6" min. straight pull trim by Von Duprin or by others.
 - (2) Von Duprin PS873 power supply. Supplies power for two EL panic devices. For two additional EL panic devices specify PS873-2.
 - (3) Wire transfer (Von Duprin or equal)
 - (a) EPT-2 for new aluminum door systems, butt hinge or offset pivot.
 - (b) DL12 for steel doors and frames or existing aluminum door systems.
 - (4) Magnetic door position switch.
 - (a) Von Duprin MS764 concealed magnetic switch.
 - (b) Folger Adam ASSW05A concealed magnetic switch.

UMC Card Access & Electronic Locking Architectural Door Hardware

- iii. A 12" x 12" x 6" junction box located above the ceiling, near the door. See detail for conduit and wire sizes.

Note: First opening components may be substituted with a Von Duprin EL99NL electric rim panic.

- g. System for pair of doors without a center mullion with rim panic device.
 - i. Active door leaf
 - (1) Von Duprin 99NL rim panic with 6" min. straight pull trim.
 - ii. Inactive door leaf
 - (1) Folger Adam 310-4-100 x NFS x 24VACSO x PK x LBM x finish or Von Duprin 6121 x FSE x DS x SO24 x finish electric strike with latch bolt monitor.
 - (2) 110VAC to 24VAC at 40VA transformer.
 - (3) Self latching flush bolts with dust proof strike.
 - (a) Metal door: Ives 559 top and 357 bottom with 489 dust proof strike, or Rockwood 1845 top and bottom with 1880 dust proof strike, or Glynn-Johnson FB9 with DP2 dust proof strike.
 - (b) Wood door: Ives 356 top and bottom with 489 dust proof strike, or Rockwood 1945 top and bottom with 1880 dust proof strike, or Glynn-Johnson FB10 with DP2 dust proof strike.
 - iii. Frame opening
 - (1) Door coordinator. There are two types of coordinators. One with an extended arm mounted above the door head on the frame=~~s~~ >exterior= may be used where appearance and vandalism are not major concerns. The other style is less visible and is surface mounted inside the opening at the frame head.
 - (a) Extended arm coordinator: Ives 469 or 469 2, or Rockwood 576, or Glynn-Johnson COR-65 door coordinator.
 - (b) Low profile coordinator: Ives 900 series, or Rockwood 1600, or Glynn-Johnson COR-* series with filler. (The specific model number is based on door size and equal or unequal pairs.)
 - iv. A 12" x 12" x 6" junction box located above the ceiling, near the door. See detail for conduit and wire sizes.
- h. System for pair of doors without a center mullion with cylindrical or mortice device.
 - i. Active door leaf
 - (1) Best 93K-7-D-14D-N/A-finish cylindrical lock or Best 35H-7-EW-14-M-finish-door hand mortice lock.
 - ii. Inactive door leaf

**UMC Card Access & Electronic Locking
Architectural Door Hardware**

- (1) Folger Adam 310-2 3/4 x NFS x 24VACSO x PK x LBM x finish or Von Duprin 6224 x FSE x DS x SO24 x finish electric strike with latch bolt monitor.
- (2) 110VAC to 24VAC

**UMC Card Access & Electronic Locking
Architectural Door Hardware**

UMC Card Access & Electronic Locking Architectural Door Hardware

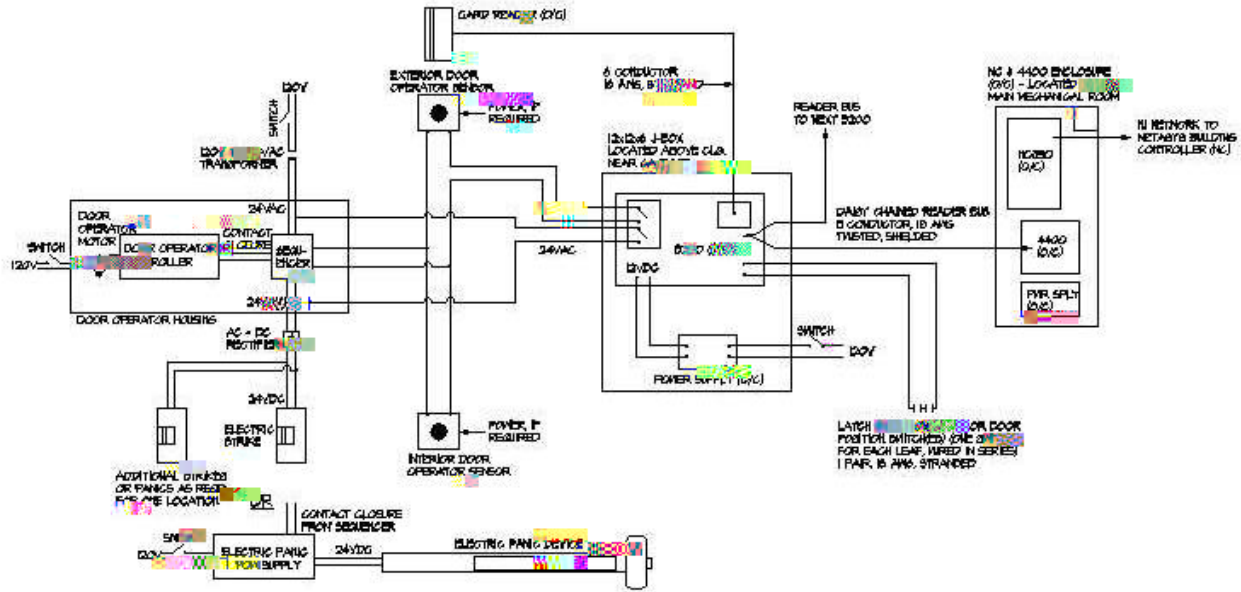

NOTES:

1. ALL LOW VOLTAGE WIRING IS TO BE MINIMUM 24 AWG UNLESS APPROVED BY OWNER REPRESENTATIVE.
2. ALL LOW VOLTAGE WIRING IS TO BE MINIMUM 18 AWG OR MINIMUM 18 AWG TWISTED SHIELDED PAIR UNLESS SPECIFIED OTHERWISE OR REQUIRED BY THE DEVICE.
3. ALL OTHER COMPONENTS ARE CONTRACTOR PROVIDED AND CONTRACTOR INSTALLED.
4. ALL TERMINATION POINTS AT THE CARD READER, 5000, 4400 AND 10000 ARE DONE BY OWNER.
5. THE POWER SUPPLY ON THE DOOR OPERATOR MUST BE USED.

SEQUENCE OPERATION:

1. DOOR OPERATOR MOTOR SHALL ENERGIZE THE LOCKING DEVICE AND THE DOOR OPERATOR MOTOR SHALL REMAIN A ONE SECOND (1) MINUTE AFTER THE DOOR OPERATOR SENSORS ARE ACTIVATED.
2. LOCKED HOURS WILL BE DETERMINED BY METAPIS.
3. DURING UNLOCKED HOURS THE 5000 WILL ENERGIZE THE LOCKING DEVICE AND ENABLE THE EXTERIOR DOOR OPERATOR MOTOR.
4. DURING LOCKED HOURS THE 5000 WILL DE-ENERGIZE THE LOCKING DEVICE AND DISABLE THE EXTERIOR DOOR OPERATOR MOTOR UNLESS A CARD IS READ BY THE CARD READER.
5. INTERIOR DOOR OPERATOR SHALL REMAIN OPERABLE AT ALL TIMES.

CARD ACCESS DOOR WITH LOW POWER OPERATOR

UMC Card Access & Electronic Locking Architectural Door Hardware

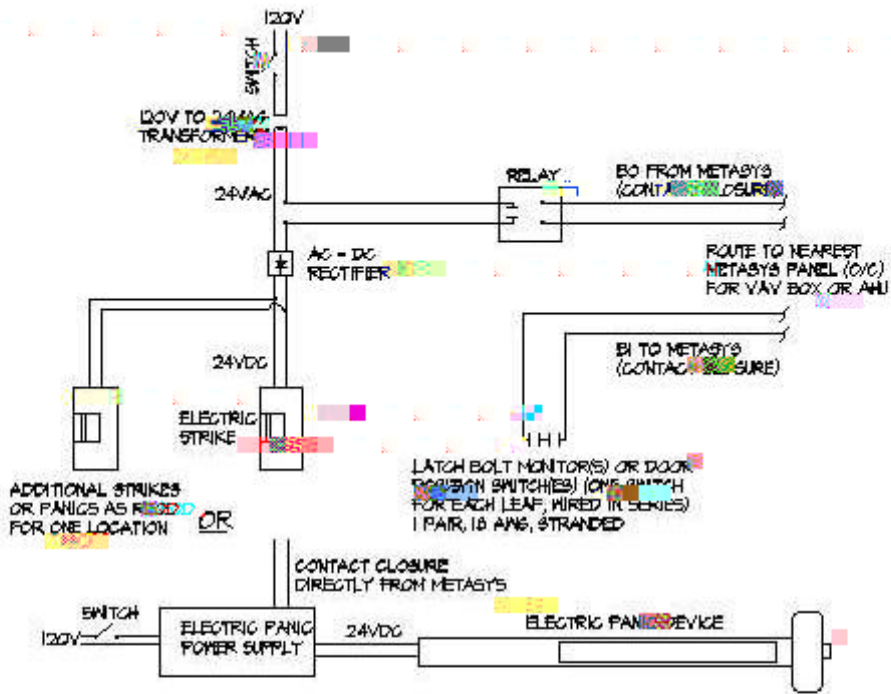

NOTES:

1. ALL WIRING IN MINIMUM 3/4" CONDUIT UNLESS APPROVED BY OWNER'S REPRESENTATIVE.
2. ALL 120V VOLTAGE WIRING (K 120V) TO BE MINIMUM 18 AWG, TWISTED SHIELDED PAIR UNLESS SPECIFIED OTHERWISE OR SUPPLIED BY THE DEVICE.
3. O/C = OWNER PROVIDED; CONTRACTOR INSTALLED. ALL OTHER COMPONENTS PROVIDED AND CONTRACTOR INSTALLED.
4. ALL TERMINATION CONNECTIONS AT THE METASYS PANEL ARE DONE BY OWNER.

SEQUENCE OF OPERATION

1. LOCKED HOURS WILL BE DETERMINED BY SYS.
2. DURING UNLOCKED HOURS, METASYS WILL DE-ENERGIZE THE LOCKING DEVICE.
3. DURING LOCKED HOURS, METASYS WILL DE-ENERGIZE THE LOCKING DEVICE.

AUTOMATIC LOCKING DOOR

SCALE: 1/8"

REVISED: 11/30/11

**UMC Card Access & Electronic Locking
Architectural Door Hardware**